

固態繼電器 SOLID STATE RELAY

KB20R02A
KB20R03A
KB20R04A
KB20R05A
KB20R06A

KB20RXXA SERIES



型號索引說明 Model No. Descriptions:

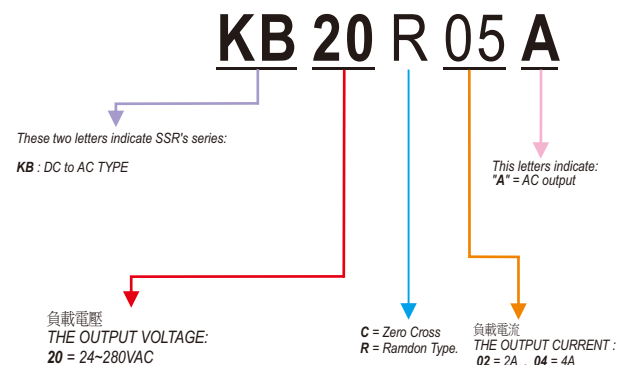

產品摘錄 PRODUCT SELECTON

輸出規格 OUTPUT SPECIFICATIONS

品名	Description	KB20R02A	KB20R03A	KB20R04A	KB20R05A	KB20R06A
負載電壓範圍	Operating Voltage [VAC]	24-280VAC	24-280VAC	24-280VAC	24-280VAC	24-280VAC
破壞電壓	Maximum Transient Overvoltage [Vpk]	600	600	600	600	600
洩露電流	Maximum Off-State Leakage Current @Rated Voltage [mA]	Less 3mA	Less 3mA	Less 3mA	Less 3mA	Less 3mA
最大瞬間承受電流	Maximum Surge Current [A] (10ms)	20A	30A	40A	50A	60A
動作壓降	Maximum On-State Voltage Drop @ Rated Current [VACrms]	1.5	1.5	1.5	1.5	1.5

輸入規格 INPUT SPECIFICATIONS

品名	Description	KB20R02A	KB20R03A	KB20R04A	KB20R05A	KB20R06A
控制電壓範圍	Control Voltage Range	3-32VDC	3-32VDC	3-32VDC	3-32VDC	3-32VDC
最小導通電壓	Minimum Turn-on Voltage	3.0	3.0	3.0	3.0	3.0
最小關斷電壓	Minimum Turn-off Voltage	1.0	1.0	1.0	1.0	1.0
輸入電流	Typical Input Current	15mA	15mA	15mA	15mA	15mA
最大動作時間	Maximum Turn-on Time [mSec]	2m Sec	2m Sec	2m Sec	2m Sec	2m Sec
最大關斷時間	Maximum Turn-off Time [mSec]	Less 1/2AC cycle	Less 1/2AC cycle	Less 1/2AC cycle	Less 1/2AC cycle	Less 1/2AC cycle

一般規格 GENERAL SPECIFICATIONS

品名	Description	KB20R02A	KB20R03A	KB20R04A	KB20R05A	KB20R06A
輸入/輸出至外殼絕緣電壓	Dielectric Strength , Input-Output Base (50/60Hz)	-	-	-	-	-
輸入/輸出絕緣電壓	Dielectric Strength , Input-Output (50/60Hz)	2500	2500	2500	2500	2500
絕緣電阻	Minimum Insulation Resistance	10 ⁹ ohm	10 ⁹ ohm	10 ⁹ ohm	10 ⁹ ohm	10 ⁹ ohm
輸入-輸出容抗	Maximum Capacitance , Input-Output	Less 15pf	Less 15pf	Less 15pf	Less 15pf	Less 15pf
工作溫度範圍	Ambient Operating Temperature Range	-20°C~+80°C	-20°C~+80°C	-20°C~+80°C	-20°C~+80°C	-20°C~+80°C
儲存溫度範圍	Ambient Storage Temperature Range	-40°C~+100°C	-40°C~+100°C	-40°C~+100°C	-40°C~+100°C	-40°C~+100°C
觸發方式	Switching Type	Ramdon Turn	Ramdon Turn	Ramdon Turn	Ramdon Turn	Ramdon Turn
重量	Weight (g)	12g	12g	12g	12g	12g

GENERAL NOTES

- (1) All parameters at 25°C unless otherwise specified
- (2) Dielectric strength and insulation resistance are measured between input and output
- (3) Heat sinking require ,for derating curves see next page.

等效電路圖 EQUIVALENT CIRCUIT

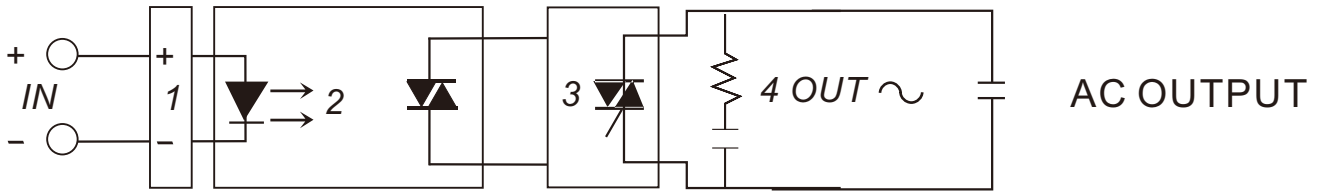

- 1.INPUT CIRCUIT
- 2.RAMDON TURN
- 3.OUTPUT CIRCUIT
- 4.PROTECTED CIRCUIT

外觀尺寸圖 MECHANICAL DIMENSIONS (Unit:mm)

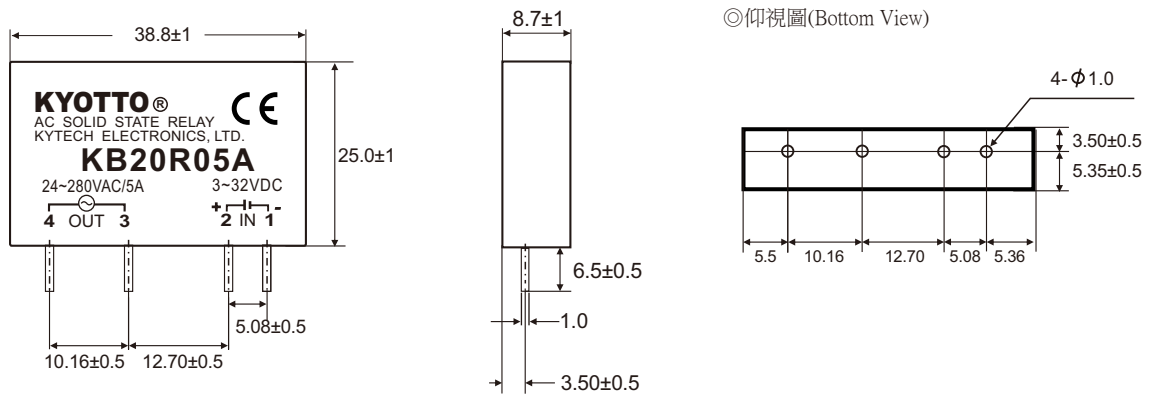

特性曲線圖 CHARACTERISTIC CURVES

