

三相固態繼電器 3 PHASE SOLID STATE RELAY

K3P20C100DA
K3P20C125DA

K3P20C- DA SERIES



型號索引說明 Model No. Descriptions:

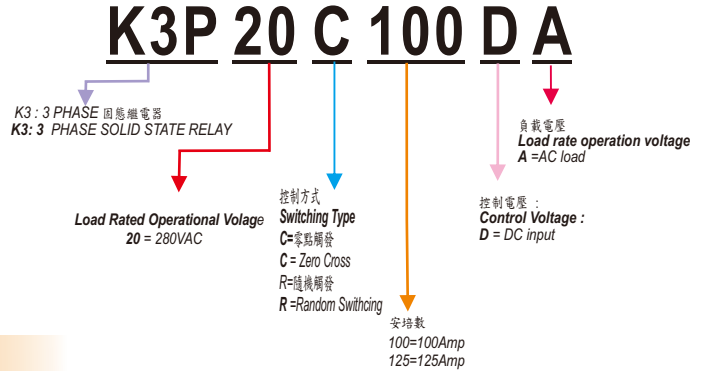

產品摘錄 PRODUCT SELECTON

輸出規格 OUTPUT SPECIFICATIONS

品名	Description	K3P20C100DA	K3P20C125DA
最大負載電流 (25°C)	Max Load Current (25°C)	100A	125A
負載電壓範圍	Operating Voltage [VAC]	24-280	24-280
破壞電壓	Maximum Transient Overvoltage [Vpk]	600	600
洩露電流	Maximum Off-State Leakage Current @Rated Voltage [mA]	Less 10m A	Less 10m A
最大瞬間承受電流	Maximum Surge Current [A] (10ms)	1000A	1250A
動作壓降	Maximum On-State Voltage Drop @ Rated Current [V]	1.5	1.5
瞬間電壓變化率	Maximum Off-State dv/dt [V/uSec]	500	500

輸入規格 INPUT SPECIFICATIONS

品名	Description	K3P20C100DA	K3P20C125DA
控制電壓範圍	Control Voltage Range	6-32VDC	6-32VDC
最小導通電壓	Minimum Turn-on Voltage	5VDC	5VDC
最小關斷電壓	Minimum Turn-off Voltage	1VDC	1VDC
輸入洩漏電流	Leakage Current	15mA	15mA
最大動作時間	Maximum Turn-on Time [msec]	Less 8.3m Sec	Less 8.3m Sec
最大關斷時間	Maximum Turn-off Time [msec]	Less 1/2AC cycle	Less 1/2AC cycle

一般規格 GENERAL SPECIFICATIONS

品名	Description	K3P20C100DA	K3P20C125DA
輸入/輸出至外殼絕緣電壓	Dielectric Strength , Input-Output Base	4000	4000
輸入/輸出絕緣電壓	Dielectric Strength , Input-Output	4000	4000
絕緣電阻	Minimum Insulation Resistance	10 ⁹ ohm	10 ⁹ ohm
工作溫度範圍	Ambient Operating Temperature Range	-20°C~+80°C	-20°C~+80°C
儲存溫度範圍	Ambient Storage Temperature Range	-40°C~+100°C	-40°C~+100°C
觸發方式	Switching Type	Zero Cross	Zero Cross
重量	Weight (g) +/- 50g	500g	500g

GENERAL NOTES

- (1) All parameters at 25°C unless otherwise specified
- (2) Dielectric strength and insulation resistance are measured between input and output
- (3) Heat sinking require , for derating curves see next page.

等效電路圖 EQUIVALENT CIRCUIT

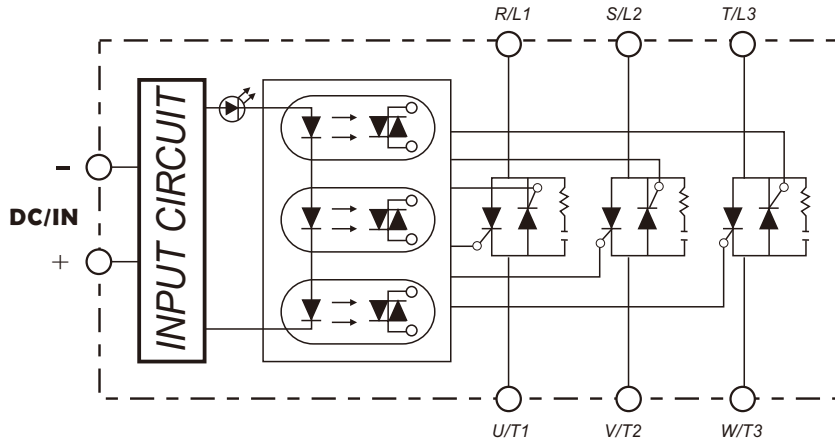

外觀尺寸圖 MECHANICAL DIMENSIONS (Unit:mm)

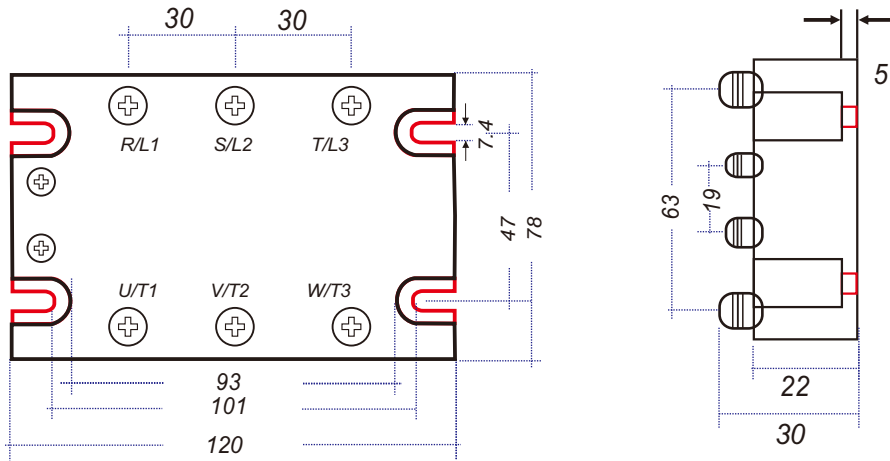

特性曲線圖 CHARACTERISTIC CURVES

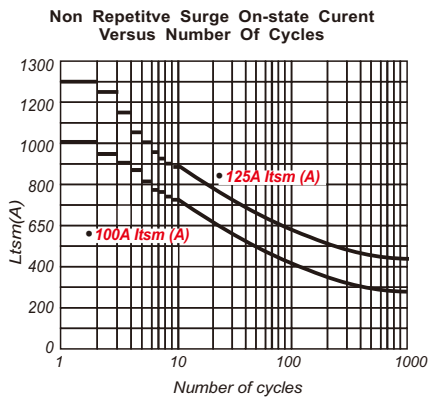
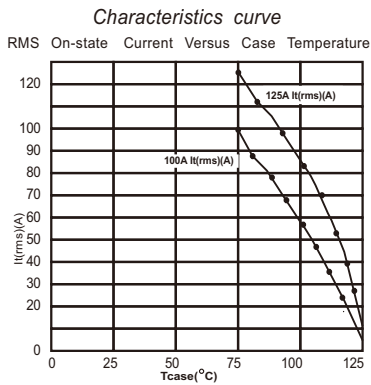

應用範例 EXAMPLE APPLICATION

