

KYOTTO[®]

Solid State Relay

固態繼電器 專業設計 · 製造

 [®]
C US
E206919



 















自動化產業 最佳首選

高品質 壽命長 無接點 無電弧
無噪音 低漏電 低壓降 高穩定



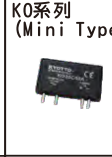

KYTECH ELECTRONICS LTD.
KYOTTO ELECTRONICS CO., LTD.

 www.kyotto.com
 www.kyotto.com.tw
 kyotto@kyotto.com









產品外觀 Appearance																		
型號 Model No. Series	KA20C02A KA20C04A		KB20C02A KB20C03A KB20C04A KB20C05A KB20C06A		KB40C02A KB40C03A KB40C04A KB40C05A KB40C06A		KC2010AX KC2015AX KC2025AX KC2040AX KC2050AX KC2075AX		KC4010AX KC4015AX KC4025AX KC4040AX KC4050AX KC4075AX		KD20C10AX KD20C15AX KD20C25AX KD20C40AX KD20C50AX KD20C75AX KD20C90AX KD20C100AX KD20C125AX		KD40C10AX KD40C15AX KD40C25AX KD40C40AX KD40C50AX KD40C75AX KD40C90AX KD40C100AX KD40C125AX		KE0602D KE0604D		KE2002D KE2004D	
控制電壓範圍 Control Voltage	3-32VDC		3-32VDC		4-20mA / 0-10VDC		4-32VDC		3-32VDC									
最大截止電壓 Must Trun Off Voltage	Max 1.0 VDC		Max 1.0 VDC		Max 3.0 VDC		Max 3.0 VDC		Max 1.0 VDC									
負載電壓範圍 Load Voltage	24-280VAC		24-280VAC		24-480VAC		180-280VAC		380-480VAC		24-280VAC		48-480VAC		3-60VDC		5-200VDC	
負載電流 (25°C) Max Load Current	2A, 4A		2A, 3A,4A,5A,6A		10A,15A,25A,40A,50A,75A		10A,15A,25A,40A		50A,75A,90A,100A,125A		2A, 4A							
破壞電壓 Blocking Voltage	600VAC _{peak}		600VAC _{peak}		1200VAC _{peak}		600VAC _{peak}		1200VAC _{peak}		600VAC _{peak}		1200VAC _{peak}		80VDC _{peak}		300VDC _{peak}	
洩漏電流 Max. Off-State Leakage	Less 3mA		Less 3mA		Less 3mA		Less 3mA		Less 3mA		Less 3mA		Less 3mA		Less 3mA		Less 3mA	
最大瞬間承受電流 Max. 1-cycle surge	20A,40A		20A,30A,40A,50A,60A		100A,150A,250A, 400A,500A,750A		100A,150A,250A,400A,500A		750A,900A,1000A,1250A		3A, 8.5A							
觸發方式 Switching Type	零點觸發 Zero Cross		零點觸發 Zero Cross		相位控制 Phase Control		零點觸發 Zero Cross		電晶體		MOSFET							
重量 (g) Weight (approx.)	15g		15g		100g		100g		100g		15g							
圖示尺寸 Graphic Size	Fig. 1		Fig. 2		Fig. 4		Fig. 4		Fig. 4		Fig. 1							

產品外觀 Appearance													
型號 Model No. Series	KR2010AX KR2015AX KR2025AX KR2040AX KR2050AX KR2075AX KR2090AX		KR4010AX KR4015AX KR4025AX KR4040AX KR4050AX KR4075AX KR4090AX		KS2002A	KS4002A	KS0602D	KT20C08A KT20C12A KT20C16A	KT20R08A KT20R12A KT20R16A	KT1008D	KO20C02A	NC20C10DA NC20C15DA NC20C25DA NC20C40DA	NC20C10AA NC20C15AA NC20C25AA NC20C40AA
控制電壓範圍 Control Voltage	VRO-250K VRO-500K		VRO-1M		3-32VDC		3-32VDC	3-32VDC	3-32VDC	3-32VDC	3-32VDC	4-32VDC	80-280VAC
最大截止電壓 Must Trun Off Voltage	Max 3.0 VDC		Max 1.0 VDC		Max 1.0 VDC	Max 1.0 VDC	Max 1.0 VDC	Max 1.0 VDC	Max 1.0 VDC	Max 1.0 VDC	Max 1.0 VDC	Max 3.0 VDC	Max 10 VAC
負載電壓範圍 Load Voltage	24-280VAC		48-480VAC		24-280VAC		48-480VAC	3-60VDC	24-280VAC	5-120VDC	12-280VAC	24-280VAC	24-280VAC
負載電流 (25°C) Max Load Current	10A,15A,25A, 40A,50A,75A,90A		2A		2A	8A,12A,16A	8A	2A	10A,15A,25A,40A				
破壞電壓 Blocking Voltage	600VAC _{peak}		1200VAC _{peak}		600VAC _{peak}		1200VAC _{peak}	80VDC _{peak}	600VAC _{peak}	80VDC _{peak}	600VAC _{peak}	600VAC _{peak}	600VAC _{peak}
洩漏電流 Max. Off-State Leakage	Less 3mA		Less 5mA		Less 3mA	Less 3mA	Less 3mA	Less 3mA	Less 3mA	Less 3mA	Less 3mA	Less 3mA	Less 3mA
最大瞬間承受電流 Max. 1-cycle surge	100A,150A,250A 400A,500A,750A,900A		20A		3.5A	80A,120A,160A	40A	20A	100A,150A,250A,400A				
觸發方式 Switching Type	相位控制 Phase Control		零點觸發 Zero Cross		電晶體	零點觸發 隨機觸發	電晶體	零點觸發 隨機觸發	零點觸發 隨機觸發	零點觸發 隨機觸發	零點觸發 隨機觸發	零點觸發 隨機觸發	零點觸發 隨機觸發
重量 (g) Weight (approx.)	100g		6g		6g	10g	10g	3.5g	100g				
圖示尺寸 Graphic Size	Fig. 4		Fig. 3		Fig. 3	Fig. 5	Fig. 5	Fig. 9	Fig. 4				

										
KF0602D KF0604D KF1002D KF1004D	KF2002D KF2004D	KG1005D KG1010D KG2010D	KG1025D KG1040D KG1050D KG1075D KG2025D KG2040D KG2050D KG2075D	KG1200-05D KG1200-10D KG1200-25D KG1200-40D	KL20C10AX KL20C15AX KL20C25AX KL20C40AX KL20C50AX KL20C75AX KL20C90AX KL20C100AX KL20C125AX	KL40C10AX KL40C15AX KL40C25AX KL40C40AX KL40C50AX KL40C75AX KL40C90AX KL40C100AX KL40C125AX	KM20C02A KM20C04A KM20C06A	KN0602D KN0604D	KN1010D KN1025D KN1040D	KN2010D KN2025D KN2040D
3-32VDC	3-32VDC	3-32VDC 4-32VDC	4-32VDC	4-32VDC	80-280VAC		80-280VAC	80-280VAC	80-280VAC	
Max 1.0 VDC	Max 1.0 VDC	Max 1.0 VDC		Max 1.0 VDC	Max 10 VAC		Max 10 VAC	Max 10 VAC	Max 10 VAC	
3-60VDC 3-120VDC	3-240VDC	5-120VDC	5-240VDC	1200VDC	24-280VAC	48-480VAC	24-280VAC	3-60VDC	5-120VDC	5-240VDC
2A, 4A	2A, 4A	5A, 10A, 15A 25A, 40A, 50A, 75A		5A, 10A, 25A, 40A	10A, 15A, 25A, 40A 50A, 75A, 90A, 100A, 125A		2A, 4A, 6A	2A, 4A	10A, 25A, 40A	
80VDC _{peak} 200VDC _{peak}	300VDC _{peak}	200VDC _{peak}	300VDC _{peak}	1200VDC _{peak}	600VAC _{peak}	1200VAC _{peak}	600VAC _{peak}	80VDC _{peak}	80VDC _{peak}	
Less 3mA	Less 3mA	Less 3mA		Less 3mA	Less 3mA		Less 3mA	Less 3mA	Less 3mA	
3A, 8.5A	3A, 8.5A	15A, 25A, 43A 52A, 75A, 150A		20A, 25A, 30A, 45A	100A, 150A, 250A, 400A, 500A 750A, 900A, 1000A, 1250A		20A, 40A, 60A	3A, 8.5A	25A, 43A, 52A	
電晶體	MOSFET	電晶體	MOSFET	IGBT	零點觸發 Zero Cross		零點觸發 Zero Cross	電晶體	MOSFET	
15g	15g	100g		100g	100g		15g	15g	100g	
Fig. 2	Fig. 2	Fig. 4		Fig. 4	Fig. 4		Fig. 2	Fig. 2	Fig. 4	

										
(W/LED)	(W/LED)			(W/LED)						
KB20C02AX KB20C03AX KB20C04AX KB20C05AX KB20C06AX KB40C02AX KB40C03AX KB40C04AX KB40C05AX KB40C06AX	KF0602DX KF0604DX	IO-1-KB20C02AX IO-1-KB20C03AX IO-1-KB20C04AX IO-1-KB20C05AX IO-1-KB20C06AX	IO-1-KB40C02AX IO-1-KB40C03AX IO-1-KB40C04AX IO-1-KB40C05AX IO-1-KB40C06AX	IO-1-KF0602DX IO-1-KF0604DX	IO-1-KB20C04A IO-2-KB20C04A IO-4-KB20C04A IO-8-KB20C04A IO-1-KB40C04A IO-2-KB40C04A IO-4-KB40C04A IO-8-KB40C04A	COM(+) COM(-) COM(+) COM(-) COM(+) COM(-) COM(+) COM(-)	IO-1-KF0604D IO-2-KF0604D IO-4-KF0604D IO-8-KF0604D IO-1-KF1004D IO-2-KF1004D IO-4-KF1004D IO-8-KF1004D	COM(+) COM(-) COM(+) COM(-) COM(+) COM(-) COM(+) COM(-)	IO-1-KF2004D IO-2-KF2004D IO-4-KF2004D IO-8-KF2004D	COM(+) COM(-) COM(+) COM(-) COM(+) COM(-) COM(+) COM(-)
4-32VDC	4-32VDC	4-32VDC	4-32VDC	4-32VDC	4-32VDC		4-32VDC	4-32VDC	4-32VDC	
Max 1.0 VDC	Max 1.0 VDC	Max 1.0 VDC	Max 1.0 VDC	Max 1.0 VDC	Max 1.0 VDC		Max 1.0 VDC	Max 1.0 VDC	Max 1.0 VDC	
24-280VAC 24-480VAC	3-60VDC	24-280VAC	24-480VAC	3-60VDC	24-280VAC	24-480VAC	3-60VDC	3-120VDC	3-240VDC	
2A, 3A, 4A, 5A, 6A	2A, 4A	2A, 3A, 4A, 5A, 6A	2A, 3A, 4A, 5A, 6A	2A, 4A	2A, 3A, 4A, 5A, 6A		2A, 4A		2A, 4A	
600VAC _{peak} 1200VAC _{peak}	80VDC _{peak}	600VAC _{peak}	1200VAC _{peak}	80VDC _{peak}	600VAC _{peak}	1200VAC _{peak}	80VDC _{peak}	200VDC _{peak}	300VDC _{peak}	
Less 3mA	Less 3mA	Less 3mA	Less 3mA	Less 3mA	Less 3mA		Less 3mA		Less 3mA	
20A, 30A, 40A 50A, 60A	3A, 8.5A	20A, 30A, 40A 50A, 60A	20A, 30A, 40A 50A, 60A	3A, 8.5A	20A, 30A, 40A, 50A, 60A		3A, 8.5A		3A, 8.5A	
零點觸發 Zero Cross	電晶體	零點觸發 Zero Cross	零點觸發 Zero Cross	電晶體	零點觸發 Zero Cross		電晶體		MOSFET	
15g	15g	40g	40g	40g	1port:33g 2port:73g		4port:128g 8port:236g			
Fig. 2	Fig. 2	Fig. 7	Fig. 7	Fig. 7	Fig. 7					

三相固態繼電器 3 PHASE SOLID STATE RELAY				三相固態繼電器 3 PHASE 2 LINE SERIES			
C = Zero Cross R = Random Switching 		C = Zero Cross R = Random Switching 		C = Zero Cross R = Random Switching 		C = Zero Cross R = Random Switching 	
K3P20C25DA K3P20C90DA	K3P40C25DA K3P40C90DA	K3P20C25AA K3P20C90AA	K3P40C25AA K3P40C90AA	K3P20C25DA-2L K3P20C90DA-2L	K3P40C25DA-2L K3P40C90DA-2L	K3P20C25AA-2L K3P20C90AA-2L	K3P40C25AA-2L K3P40C90AA-2L
K3P20R25DA K3P20R90DA	K3P40R25DA K3P40R90DA	K3P20R25AA K3P20R90AA	K3P40R25AA K3P40R90AA	K3P20R25DA-2L K3P20R90DA-2L	K3P40R25DA-2L K3P40R90DA-2L	K3P20R25AA-2L K3P20R90AA-2L	K3P40R25AA-2L K3P40R90AA-2L
6-32VDC	12-32VDC	80-280VAC	80-280VAC	5-32VDC	10-32VDC	80-280VAC	80-280VAC
Max 3.0VDC	Max 3.0VDC	Max 10VAC	Max 10VAC	Max 3.0VDC	Max 3.0VDC	Max 10VAC	Max 10VAC
24-280VAC	48-480VAC	24-280VAC	48-480VAC	24-280VAC	48-480VAC	24-280VAC	48-480VAC
25A,40A,50A 75A,90A	25A,40A,50A 75A,90A	25A,40A,50A 75A,90A	25A,40A,50A 75A,90A	25A,40A,50A 75A,90A	25A,40A,50A 75A,90A	25A,40A,50A 75A,90A	25A,40A,50A 75A,90A
600VAC _{peak}	1200VAC _{peak}	600VAC _{peak}	1200VAC _{peak}	600VAC _{peak}	1200VAC _{peak}	600VAC _{peak}	1200VAC _{peak}
Less 10mA	Less 10mA	Less 10mA	Less 10mA	Less 10mA	Less 10mA	Less 10mA	Less 10mA
250A,400A,500A 750A,900A	250A,400A,500A 750A,900A	250A,400A,500A 750A,900A	250A,400A,500A 750A,900A	250A,400A,500A 750A,900A	250A,400A,500A 750A,900A	250A,400A,500A 750A,900A	250A,400A,500A 750A,900A
零點觸發 Zero Cross	隨機觸發 Random Switching	零點觸發 Zero Cross	隨機觸發 Random Switching	零點觸發 Zero Cross	隨機觸發 Random Switching	零點觸發 Zero Cross	隨機觸發 Random Switching
400g	400g	400g	400g	400g	400g	400g	400g
Fig. 8	Fig. 8	Fig. 8	Fig. 8	Fig. 8	Fig. 8	Fig. 8	Fig. 8

三相馬達正逆轉固態繼電器 3 PHASE SOLID STATE REVERSING RELAY		三相固態繼電器 3 PHASE SOLID STATE RELAY		三相固態繼電器 3 PHASE 2 LINE SERIES		單相兩線固態繼電器 1 PHASE SOLID STATE RELAY	
 		 		 		 	
C = Zero Cross R = Random Switching		C = Zero Cross R = Random Switching		C = Zero Cross R = Random Switching		C = Zero Cross R = Random Switching	
K2R480C1DA K2R480C2DA K2R480C3DA K2R480C4DA K2R480C5DA K2R480C7DA	K2R480C1AA K2R480C2AA K2R480C3AA K2R480C4AA K2R480C5AA K2R480C7AA	K3P20C100DA K3P20C125DA K3P40C100DA K3P40C125DA K3P20R100DA K3P20R125DA K3P40R100DA K3P40R125DA	K3P20C100AA K3P20C125AA K3P40C100AA K3P40C125AA K3P20R100AA K3P20R125AA K3P40R100AA K3P40R125AA	K3P20C100DA-2L K3P20C125DA-2L K3P40C100DA-2L K3P40C125DA-2L K3P20R100DA-2L K3P20R125DA-2L K3P40R100DA-2L K3P40R125DA-2L	K3P20C100AA-2L K3P20C125AA-2L K3P40C100AA-2L K3P40C125AA-2L K3P20R100AA-2L K3P20R125AA-2L K3P40R100AA-2L K3P40R125AA-2L	K2P20C25DA K2P20C125DA K2P40C25DA K2P40C125DA	K2P20C25AA K2P20C125AA K2P40C25AA K2P40C125AA
10-50VDC	80-280VAC	6-32VDC 12-32VDC	80-280VAC	5-32VDC 10-32VDC	80-280VAC	5-32VDC 10-32VDC	80-280VAC
Max 2.0 VDC	Max 10 VAC	Max 3.0VDC	Max 10VAC	Max 3.0VDC	Max 10VAC	Max 2.0VDC	Max 10VAC
48-480VAC	48-480VAC	24-280VAC 48-480VAC	24-280VAC 48-480VAC	24-280VAC 48-480VAC	24-280VAC 48-480VAC	24-280VAC 48-480VAC	24-280VAC 48-480VAC
1HP(0.75kW),2HP(1.5kW) 3HP(2.2kW),4HP(3.0kW) 5HP(4.0kW),7.5HP(5.5kW)	1HP(0.75kW),2HP(1.5kW) 3HP(2.2kW),4HP(3.0kW) 5HP(4.0kW),7.5HP(5.5kW)	100A,125A	100A,125A	100A,125A	100A,125A	25A,40A,50A 75A,90A,100A,125A	25A,40A,50A 75A,90A,100A,125A
1200VAC _{peak}	1200VAC _{peak}	600VAC _{peak} 1200VAC _{peak}	600VAC _{peak} 1200VAC _{peak}	600VAC _{peak} 1200VAC _{peak}	600VAC _{peak} 1200VAC _{peak}	600VAC _{peak} 1200VAC _{peak}	600VAC _{peak} 1200VAC _{peak}
Less 10mA	Less 10mA	Less 10mA	Less 10mA	Less 10mA	Less 10mA	Less 10mA	Less 10mA
100A,200A,300A 400A,500A,700A	100A,200A,300A 400A,500A,700A	1000A,1250A	1000A,1250A	1000A,1250A	1000A,1250A	250A,400A,500A,750A 900A,1000A,1250A	250A,400A,500A,750A 900A,1000A,1250A
零點觸發 Zero Cross	隨機觸發 Random Switching	零點觸發 Zero Cross	隨機觸發 Random Switching	零點觸發 Zero Cross	隨機觸發 Random Switching	零點觸發 Zero Cross	隨機觸發 Random Switching
400g	400g	500g	500g	500g	500g	400g	400g
Fig. 8	Fig. 8	Fig. 10	Fig. 10	Fig. 10	Fig. 10	Fig. 8	Fig. 8

SSR Application Examples :

APPLICATION EXAMPLES

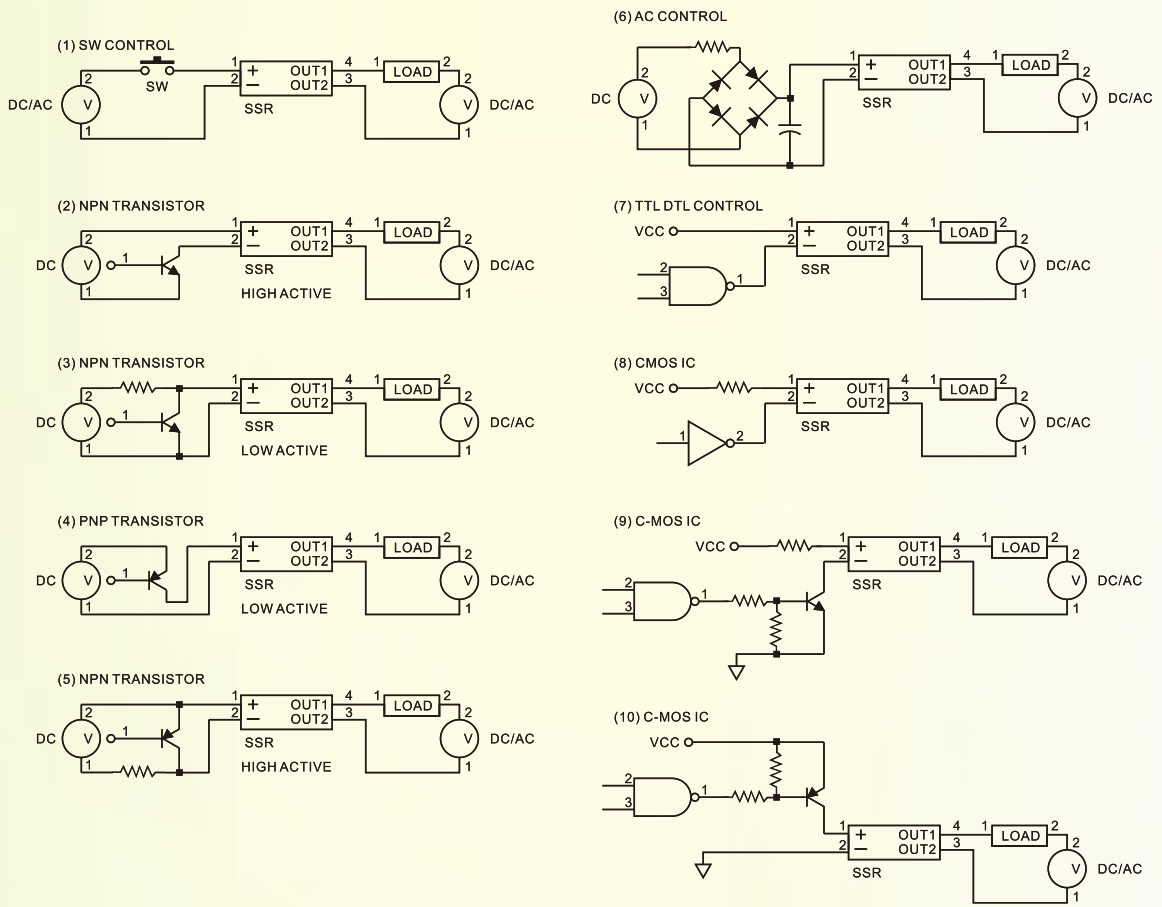

LOAD EXAMPLES

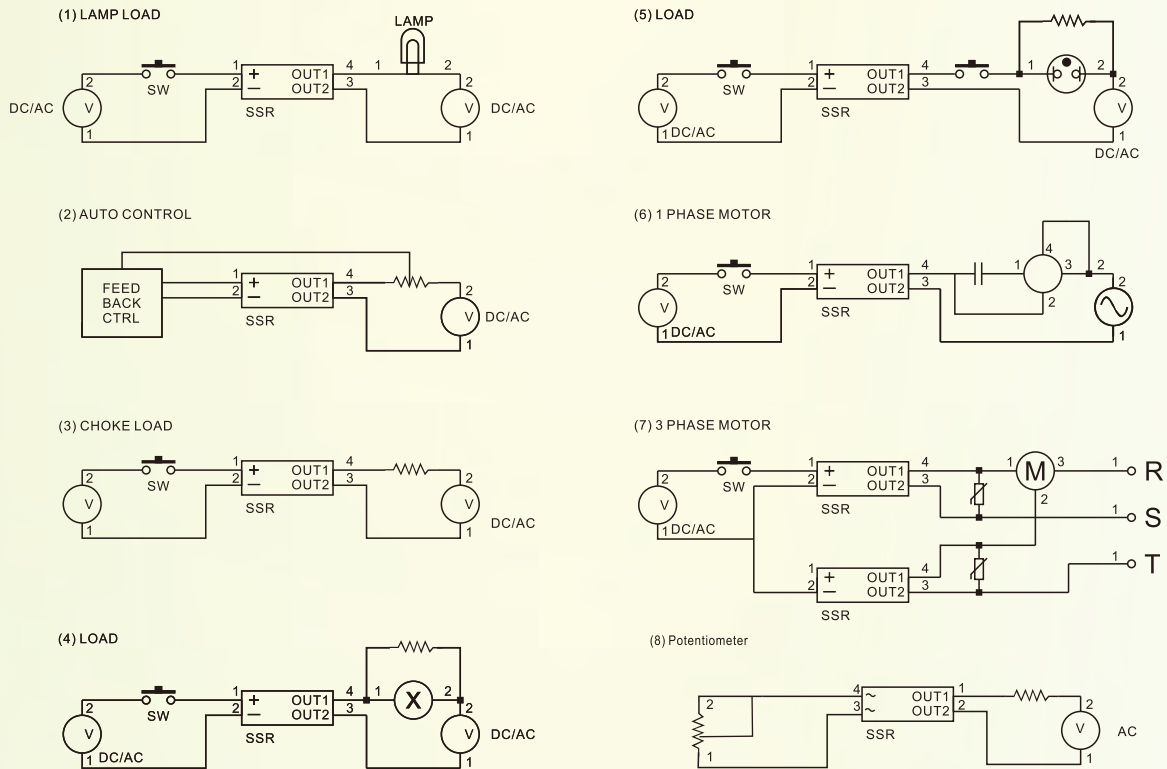

尺寸圖 Outline Dimensions:

KA/KE系列

Fig.1

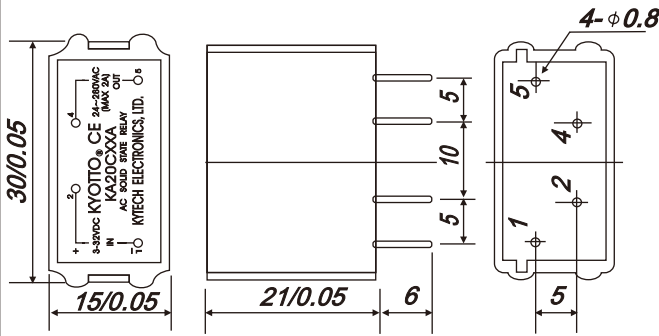

KB/KF/KM/KN 系列

Fig.2

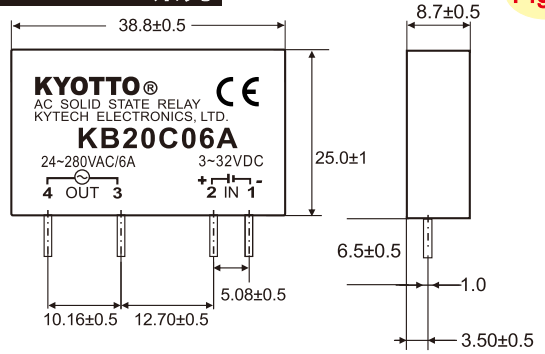

KS系列

Fig.3

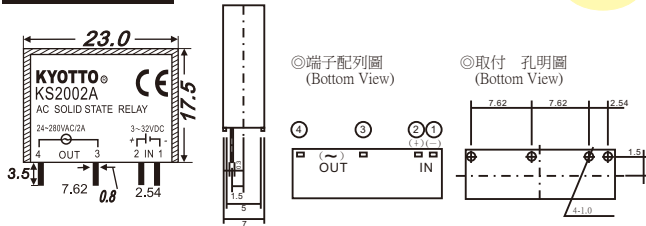

KC/KD/KG/KN/KL/KR/NC 系列

Fig.4

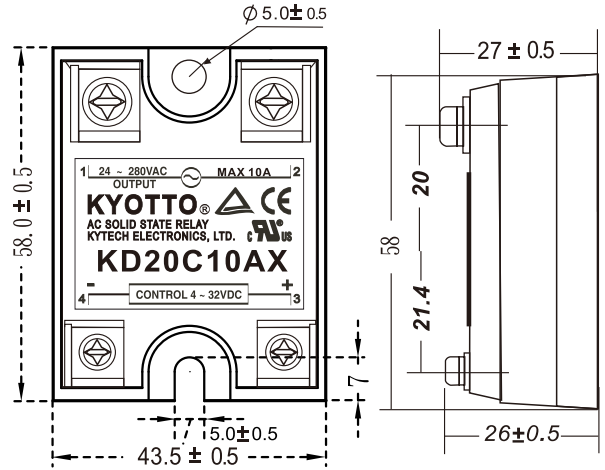

KT系列

Fig.5

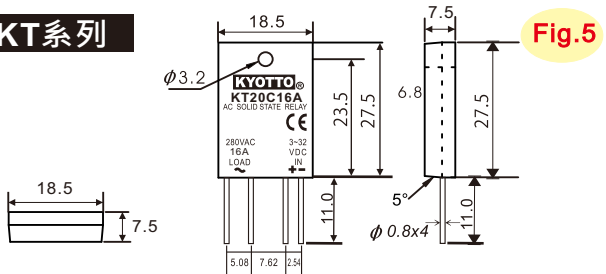

IO SOCKET 系列

Fig.6

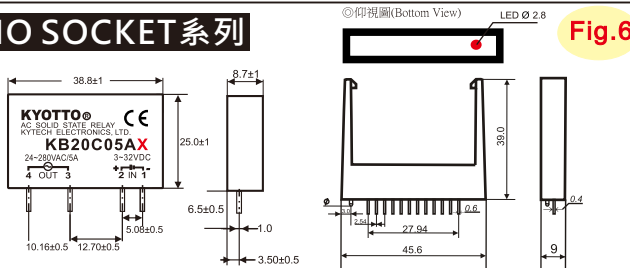

IO MODULE 系列

Fig.7

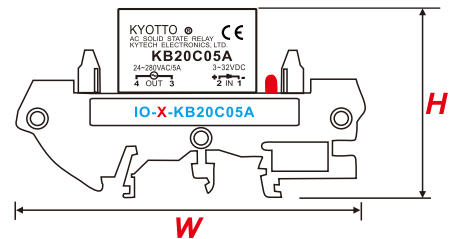

Model	Dimension (LxWxH)mm
IO-1 port	14x87x51
IO-2 port	34x87x51
IO-4 port	64x87x51
IO-8 port	124x87x51

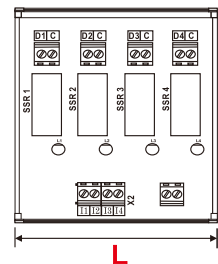

KO系列

Fig.9

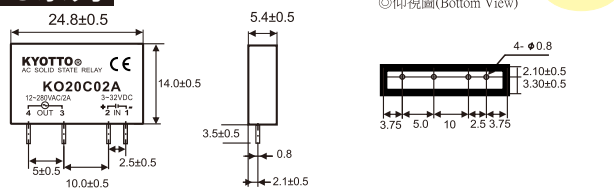

K2/K3 系列

Fig.8

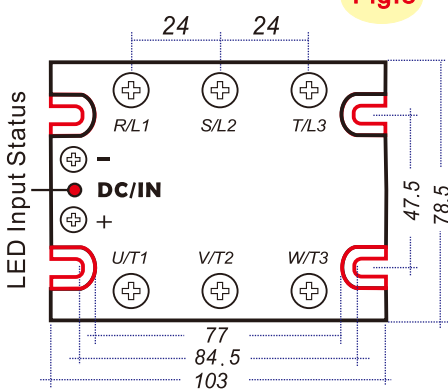
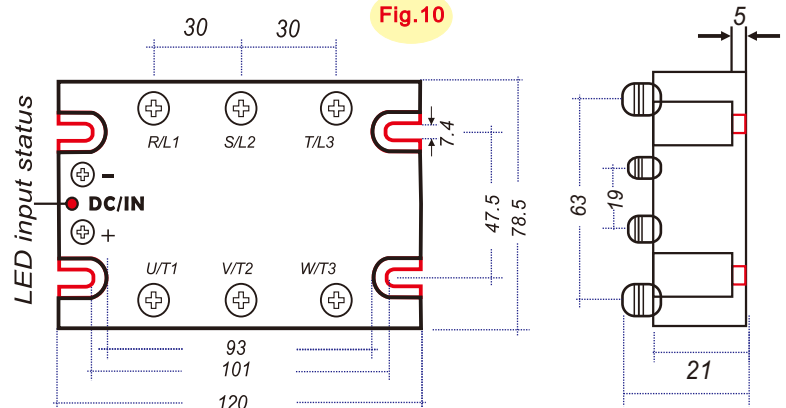
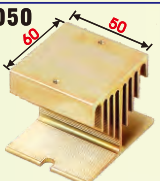
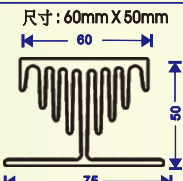

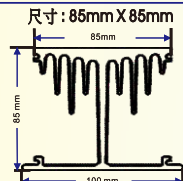

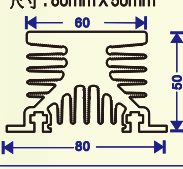
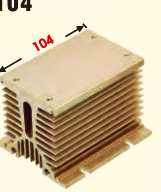
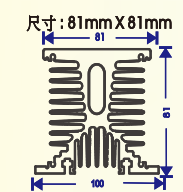
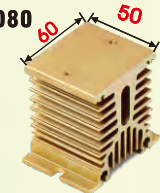
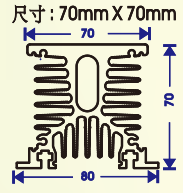
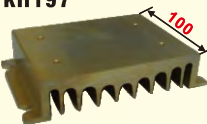
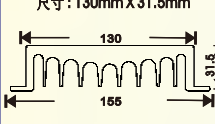
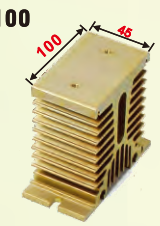
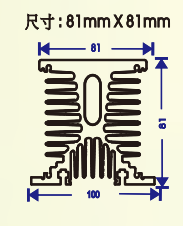
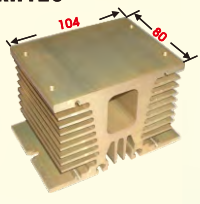
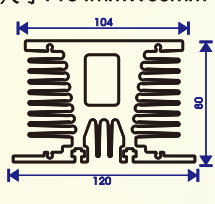
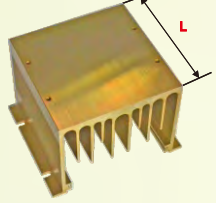
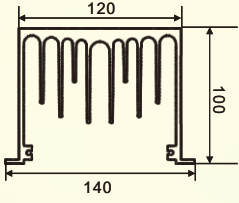

Fig.10



配 件

1. 散熱片

Appearance	Size	Suitable Specification	Appearance	Size	Suitable Specification																																							
 KH050	尺寸: 60mm X 50mm 	<table border="1"> <thead> <tr> <th>Model No</th> <th>Length L(mm)</th> <th>Suitable SSR</th> </tr> </thead> <tbody> <tr> <td>KH050-50</td> <td>50</td> <td>5A, 10A</td> </tr> </tbody> </table>	Model No	Length L(mm)	Suitable SSR	KH050-50	50	5A, 10A	 KH090	尺寸: 85mm X 85mm 	KH090 Series FOR SINGAL SSR & 3 PHASE SSR <table border="1"> <thead> <tr> <th>Model No</th> <th>Length L(mm)</th> <th>Suitable SSR</th> </tr> </thead> <tbody> <tr> <td>KH090-100</td> <td>100</td> <td>25A-75A</td> </tr> </tbody> </table>	Model No	Length L(mm)	Suitable SSR	KH090-100	100	25A-75A																											
Model No	Length L(mm)	Suitable SSR																																										
KH050-50	50	5A, 10A																																										
Model No	Length L(mm)	Suitable SSR																																										
KH090-100	100	25A-75A																																										
 KH060	尺寸: 60mm X 50mm 	<table border="1"> <thead> <tr> <th>Model No</th> <th>Length L(mm)</th> <th>Suitable SSR</th> </tr> </thead> <tbody> <tr> <td>KH060-50</td> <td>50</td> <td>10A, 15A</td> </tr> <tr> <td>KH060-80</td> <td>80</td> <td>25A</td> </tr> <tr> <td>KH060-100</td> <td>100</td> <td>40A</td> </tr> <tr> <td>KH060-120</td> <td>120</td> <td>50A</td> </tr> <tr> <td>KH060-150</td> <td>150</td> <td>75A</td> </tr> </tbody> </table>	Model No	Length L(mm)	Suitable SSR	KH060-50	50	10A, 15A	KH060-80	80	25A	KH060-100	100	40A	KH060-120	120	50A	KH060-150	150	75A	 KH104	尺寸: 81mm X 81mm 	KH104 Series FOR 3PHASE SSR <table border="1"> <thead> <tr> <th>Model No.</th> <th>L(mm)</th> <th>Suitable SSR</th> </tr> </thead> <tbody> <tr> <td>KH104-104</td> <td>104</td> <td>25A, 40A</td> </tr> <tr> <td>KH104-120</td> <td>120</td> <td>50A, 75A</td> </tr> <tr> <td>KH104-150</td> <td>150</td> <td>90A</td> </tr> <tr> <td>KH104-120(W)</td> <td>120</td> <td>100A</td> </tr> <tr> <td>KH104-150(W)</td> <td>150</td> <td>125A</td> </tr> </tbody> </table>	Model No.	L(mm)	Suitable SSR	KH104-104	104	25A, 40A	KH104-120	120	50A, 75A	KH104-150	150	90A	KH104-120(W)	120	100A	KH104-150(W)	150	125A			
Model No	Length L(mm)	Suitable SSR																																										
KH060-50	50	10A, 15A																																										
KH060-80	80	25A																																										
KH060-100	100	40A																																										
KH060-120	120	50A																																										
KH060-150	150	75A																																										
Model No.	L(mm)	Suitable SSR																																										
KH104-104	104	25A, 40A																																										
KH104-120	120	50A, 75A																																										
KH104-150	150	90A																																										
KH104-120(W)	120	100A																																										
KH104-150(W)	150	125A																																										
 KH080	尺寸: 70mm X 70mm 	<table border="1"> <thead> <tr> <th>Model No</th> <th>Length L(mm)</th> <th>Suitable SSR</th> </tr> </thead> <tbody> <tr> <td>KH080-50</td> <td>50</td> <td>25A</td> </tr> <tr> <td>KH080-100</td> <td>100</td> <td>40A</td> </tr> <tr> <td>KH080-150</td> <td>150</td> <td>50A</td> </tr> </tbody> </table>	Model No	Length L(mm)	Suitable SSR	KH080-50	50	25A	KH080-100	100	40A	KH080-150	150	50A	 KH197	尺寸: 130mm X 31.5mm 	KH197 Series FOR 3PHASE SSR <table border="1"> <thead> <tr> <th>Model No</th> <th>Length L(mm)</th> <th>Suitable SSR</th> </tr> </thead> <tbody> <tr> <td>KH197-100</td> <td>100</td> <td>25A, 40A</td> </tr> </tbody> </table>	Model No	Length L(mm)	Suitable SSR	KH197-100	100	25A, 40A																					
Model No	Length L(mm)	Suitable SSR																																										
KH080-50	50	25A																																										
KH080-100	100	40A																																										
KH080-150	150	50A																																										
Model No	Length L(mm)	Suitable SSR																																										
KH197-100	100	25A, 40A																																										
 KH100	尺寸: 81mm X 81mm 	<table border="1"> <thead> <tr> <th>Model No</th> <th>Length L(mm)</th> <th>Suitable SSR</th> </tr> </thead> <tbody> <tr> <td>KH100-45</td> <td>45</td> <td>40A</td> </tr> <tr> <td>KH100-70</td> <td>70</td> <td>50A</td> </tr> <tr> <td>KH100-100</td> <td>100</td> <td>75A</td> </tr> <tr> <td>KH100-120</td> <td>120</td> <td>90A</td> </tr> <tr> <td>KH100-150</td> <td>150</td> <td>100A</td> </tr> <tr> <td>KH100-200</td> <td>200</td> <td>125A</td> </tr> </tbody> </table>	Model No	Length L(mm)	Suitable SSR	KH100-45	45	40A	KH100-70	70	50A	KH100-100	100	75A	KH100-120	120	90A	KH100-150	150	100A	KH100-200	200	125A	 KH120	尺寸: 104mm X 80mm 	KH120 Series FOR 3PHASE SSR <table border="1"> <thead> <tr> <th>Model No</th> <th>L(mm)</th> <th>Suitable SSR</th> </tr> </thead> <tbody> <tr> <td>KH120-80</td> <td>80</td> <td>25A, 40A</td> </tr> <tr> <td>KH120-100</td> <td>100</td> <td>50A, 75A</td> </tr> <tr> <td>KH120-120</td> <td>120</td> <td>90A</td> </tr> <tr> <td>KH120-120(W)</td> <td>120</td> <td>100A</td> </tr> <tr> <td>KH120-150(W)</td> <td>150</td> <td>125A</td> </tr> </tbody> </table>	Model No	L(mm)	Suitable SSR	KH120-80	80	25A, 40A	KH120-100	100	50A, 75A	KH120-120	120	90A	KH120-120(W)	120	100A	KH120-150(W)	150	125A
Model No	Length L(mm)	Suitable SSR																																										
KH100-45	45	40A																																										
KH100-70	70	50A																																										
KH100-100	100	75A																																										
KH100-120	120	90A																																										
KH100-150	150	100A																																										
KH100-200	200	125A																																										
Model No	L(mm)	Suitable SSR																																										
KH120-80	80	25A, 40A																																										
KH120-100	100	50A, 75A																																										
KH120-120	120	90A																																										
KH120-120(W)	120	100A																																										
KH120-150(W)	150	125A																																										
 KH204(W)	尺寸: 120mm X 100mm 	<table border="1"> <thead> <tr> <th>Model No.</th> <th>Length L(mm)</th> <th>Suitable SSR</th> </tr> </thead> <tbody> <tr> <td>KH204-120(W)</td> <td>120</td> <td>100A</td> </tr> <tr> <td>KH204-150(W)</td> <td>150</td> <td>125A</td> </tr> </tbody> </table>	Model No.	Length L(mm)	Suitable SSR	KH204-120(W)	120	100A	KH204-150(W)	150	125A	KH204 Series FOR 3PHASE SSR																																
Model No.	Length L(mm)	Suitable SSR																																										
KH204-120(W)	120	100A																																										
KH204-150(W)	150	125A																																										

備註：本產品須用於散熱良好之環境，本公司備有專用散熱片，品質優異，供客戶選用。

2. 保護蓋



KSC-1 For Single Phase

3. I/O模組塑膠座

Housing			PCB		
Width	Length	Height	Width	Length	Height
87	X	28	72	Y	1.6

尺寸: X(L)x 87(W)x28(H)mm



4. 鋁軌卡勾

Rail-S

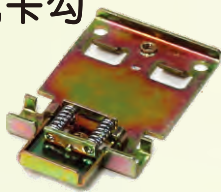

For KH050/060/080

Rail-L

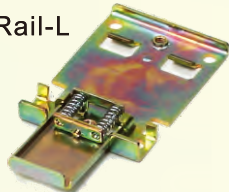

For KH100/104

5. 鋁軌



尺寸: 1000(L)x 35(W)x7.4(H)mm

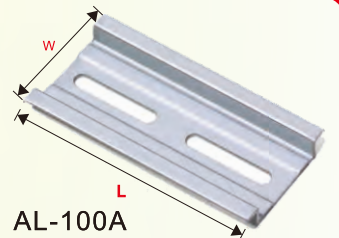

AL-100A

KYOTTO®

KYTECH ELECTRONICS LTD.
KYOTTO ELECTRONICS CO., LTD.

AUTHORIZED DISTRIBUTOR :