

# AC SOLID STATE RELAY

**K3P20R25DA    K3P20R75DA**  
**K3P20R40DA    K3P20R90DA**  
**K3P20R50DA    K3P20R100DA**

(INDUCTIVE LOAD ONLY)  
 3PHASE SERIES



## SPECIFICATIONS

MODEL NO.	CONTROL VOLTAGE RANGE	MUST TURN OFF VOLTAGE	INPUT IMPEDANCE	MAX LOAD CURRENT	LOAD VOLTAGE RANGE	MIN BLOCKING VOLTAGE	MAX OFF-STATE LEAKAGE	FREQUENCY RANGE	MAX 1-CYCLE PEAK SURGE
K3P20R25DA	6 TO 32VDC	MAX9.5VDC	1.5Kohm	25A	24~280VAC	600VAC	LESS 10 mA	47~63HZ	315A
K3P20R40DA	6 TO 32VDC	MAX9.5VDC	1.5Kohm	40A	24~280VAC	600VAC	LESS 10 mA	47~63HZ	450A
K3P20R50DA	6 TO 32VDC	MAX9.5VDC	1.5Kohm	50A	24~280VAC	600VAC	LESS 10 mA	47~63HZ	560A
K3P20R75DA	6 TO 32VDC	MAX9.5VDC	1.5Kohm	75A	24~280VAC	600VAC	LESS 10 mA	47~63HZ	700A
K3P20R90DA	6 TO 32VDC	MAX9.5VDC	1.5Kohm	90A	24~280VAC	600VAC	LESS 10 mA	47~63HZ	900A
K3P20R100DA	6 TO 32VDC	MAX9.5VDC	1.5Kohm	100A	24~280VAC	600VAC	LESS 10 mA	47~63HZ	1030A

MODEL NO.	MAX OFF STATE dv/dt	MAX ON-STATE VOLTAGE DROP	ISOLATE IMPEDENCE	DIELECTRIC STRENGTH INPUT-OUTPUT	DIELECTRIC STRENGTH INPUT-OUTPUT-CASE	TURN ON TIME	TURN OFF TIME	CAPACITANCE IN-OUT	WEIGHT (g)
K3P20R25DA	250 V/ $\mu$ SEC	1.6Vrms	$10^9$ ohm	2500Vrms	2500Vrms	LESS1/2ACcycle	LESS1/2ACcycle	LESS473pf	600 g
K3P20R40DA	250 V/ $\mu$ SEC	1.6Vrms	$10^9$ ohm	2500Vrms	2500Vrms	LESS1/2ACcycle	LESS1/2ACcycle	LESS473pf	600 g
K3P20R50DA	250 V/ $\mu$ SEC	1.6Vrms	$10^9$ ohm	2500Vrms	2500Vrms	LESS1/2ACcycle	LESS1/2ACcycle	LESS473pf	600 g
K3P20R75DA	250 V/ $\mu$ SEC	1.6Vrms	$10^9$ ohm	2500Vrms	2500Vrms	LESS1/2ACcycle	LESS1/2ACcycle	LESS473pf	600 g
K3P20R90DA	250 V/ $\mu$ SEC	1.6Vrms	$10^9$ ohm	2500Vrms	2500Vrms	LESS1/2ACcycle	LESS1/2ACcycle	LESS473pf	600 g
K3P20R100DA	250 V/ $\mu$ SEC	1.6Vrms	$10^9$ ohm	2500Vrms	2500Vrms	LESS1/2ACcycle	LESS1/2ACcycle	LESS473pf	600 g

## OUTLINE DIMENSIONS (unit:mm)

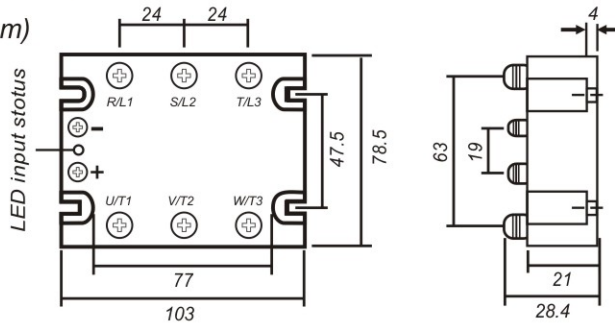

## EQUIVALENT CIRCUIT

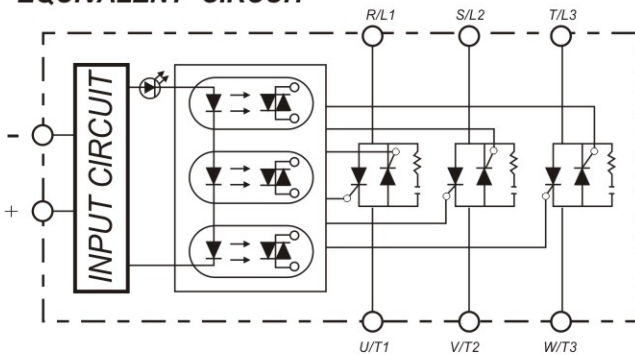

## Example of 3 $\phi$ SSR Application

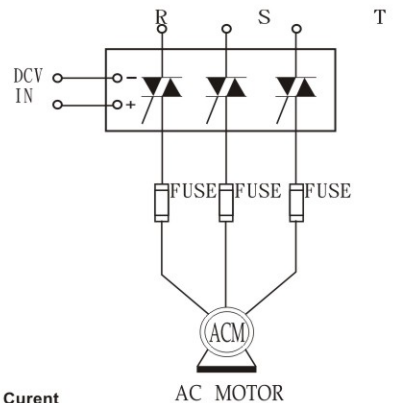

## CHARACTERISTIC CURVES

Characteristics curve

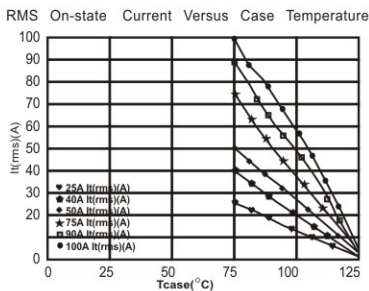

Non Repetitive Surge On-state Current Versus Number Of Cycles

